



# Coach Pitch Field Prep Guide

**Equipment:** Equipment is stored in a storage bin on the outside of the backstop. Team managers have the code to open the lockbox that contains the key to open the padlock on the storage box as well as unlock the large items chained to the fence. For the **Coach Pitch division**, you will find at each FCLL diamond:

- Pitching Machine
- Small L-Screen
- Large hitting mat with plate
- 3 Bases
- Large landscape rake

## Before the Game: Home Team Field Prep

- Walk the field and remove any debris. Ensure there is no garbage, branches, large rocks, or stones on the infield skin or outfield grass.
- Using the large landscape rake, level any low or high spots on the infield skin particularly around the bases and home plate area. Rake shale from behind each base towards the center of the diamond.
- For any areas of standing water, remove as much as possible with the large landscape rake and rake dry shale over any remaining wet areas.
- Place the large mat with the home plate point facing the backstop on top of the marker whiskers at home.
- Place a base at each of the 60' whiskers at 1<sup>st</sup> base, 2<sup>nd</sup> base, and 3<sup>rd</sup> base.
- Setup the L-Screen 30 feet from home plate between home and 2<sup>nd</sup> base.
- Setup the Pitching Machine behind the L-Screen (see next page for set up instructions).
- If the diamond has a portable toilet, unlock the portable toilet with the key on the lanyard and ensure the key is returned to the storage bin.

## After the Game: Visiting Team Field Take Down

- Both teams are responsible for ensuring their dugout/bench is clean of garbage and gear.
- Lock the portable toilet.
- Lay the landscape rake behind the storage bin and lock it to the backstop with the chain.
- Place the portable toilet key, pitching machine, mat, and bases should in the storage bin.
- Ensure the key is in the lock box, scramble the combination tumblers, and close the cover.
- Lock the storage bin with the padlock.

Let's aim to leave the field each night with it in better shape than when we arrived!

For any questions, concerns, or issues with diamonds or equipment, please email:

diamonds@fcll.ca



# Coach Pitch Field Prep Guide

## BASEBALL

Pitching machines are available at each of the Fish Creek designated Coach Pitch and Minors American League diamonds and are stored in the equipment storage bins. They may be partially disassembled to fit inside.

Begin setup by assembling the pitching machine. Attach the *Front Stabilizer* and tighten the *Front Stabilizer Knob*. Insert the *Release Handle* into the base of the pitching machine and fasten with the bolt and wingnut. Attach the spring of the *Throwing Arm* to the *Power Lever* by inserting the *Power Lever Pull Pin* to setting #3.

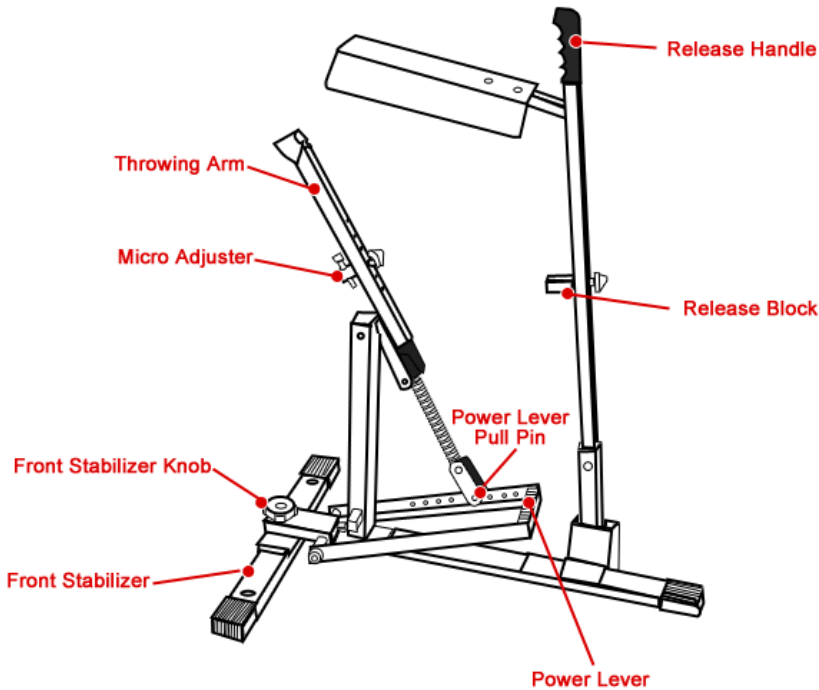

### Set Up Pitching Machine

1. Set up small L-Screen about **30 feet** from Homeplate.
2. Set Pitching machine **behind the small L-Screen**.
3. Ensure the *Release Block*, *Micro Adjuster*, and *Power Lever* are all **set to #3**.
4. These settings allow for a pitch of approximately 26 mph at 30'.

### Using the Pitching Machine

#### Load the Ball

1. Pull *Throwing Arm* back.
2. Push the *Release Handle* forward to lock the *Throwing Arm* into the *Release Block*
3. Hold the *Release Handle* and place the ball against the head of the *Micro Adjuster*. Place the ball with the logo facing up so the ball is thrown like a two-seam fastball. Continue to hold the handle forward until the ball is thrown.

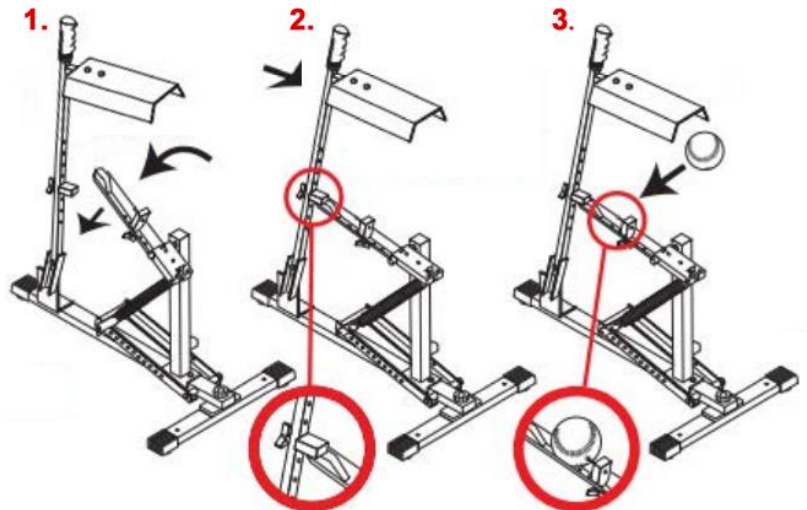

## Step on the Power Lever

4. Push the *Power Lever* with foot
5. Hold the *Power Lever* down until the ball is thrown.

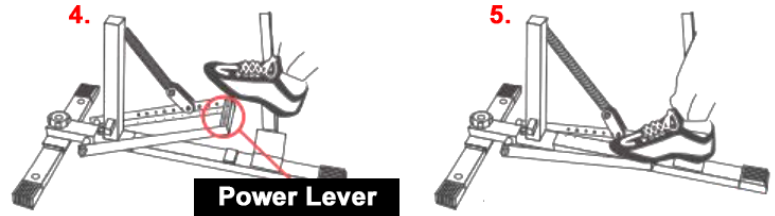

## Release the Ball

6. Slowly pull the *Release Handle* back with a smooth motion for the most accurate pitch.

## Dialing in the Pitching Machine

Once the pitching machine is setup, placed, and working, dial in the pitching machine by testing it out with a few balls and adjusting both left / right and up /down to ensure the machine is pitching through the strike zone before the game.

### Left / Right Through the Strike Zone

1. Loosen the *Front Stabilizer Knob* and angle the pitching machine in line with home plate.
2. Test the accuracy by releasing a ball.
3. Adjust the aim by moving the back foot left or right in small increments.
  - a. At a pitching distance of 30', moving the back foot  $\frac{1}{2}$ " will move the pitch up to 10" at the plate.
4. When the machine is pitching across the plate, re-tighten the *Front Stabilizer Knob*.

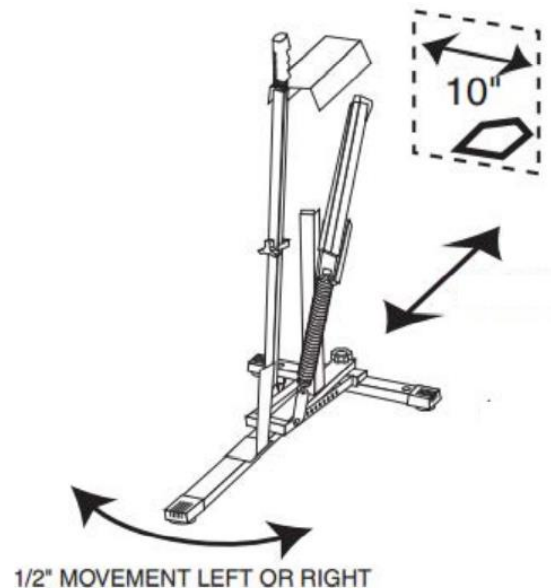

### Up / Down Through the Strike Zone

1. Turn the *Micro Adjuster*, the screw that the ball rests on when placed on the pitching arm to raise and lower the pitch
2. The *Release Block* setting can also be changed to raise and lower the pitch if the *Micro Adjuster* is not sufficient to get the ball through the strike zone.

